

4

3

2

1



REVISION DATA				
SYM	REV	DESCRIPTION	DATE	APPR.
	00	new part	03.08.17	MR

Technical Specification

Current Rating: 4A AC, DC
Voltage Rating: 250V AC,DC
Temperature: -25°C to +85°C
high temperature: on request
Contact Resistance: 10mΩ
Insulation Resistance: 1000MΩ
Withstanding Voltage: 1000V AC/minute
Material: Thermoplastic, UL94V-0

Circuit No.	Dimensions	
	A	B
02P	2.54	5.68
03P	5.08	8.22
04P	7.62	10.76
05P	10.16	13.30
06P	12.70	15.84
07P	15.24	18.38
08P	17.78	20.92
09P	20.32	23.46
10P	22.86	26.00
11P	25.40	28.54
12P	27.94	31.08
13P	30.48	33.62
14P	33.02	36.16
15P	35.56	38.70
16P	38.10	41.24
17P	40.64	43.78
18P	43.18	46.32
19P	45.72	48.86
20P	48.26	51.40

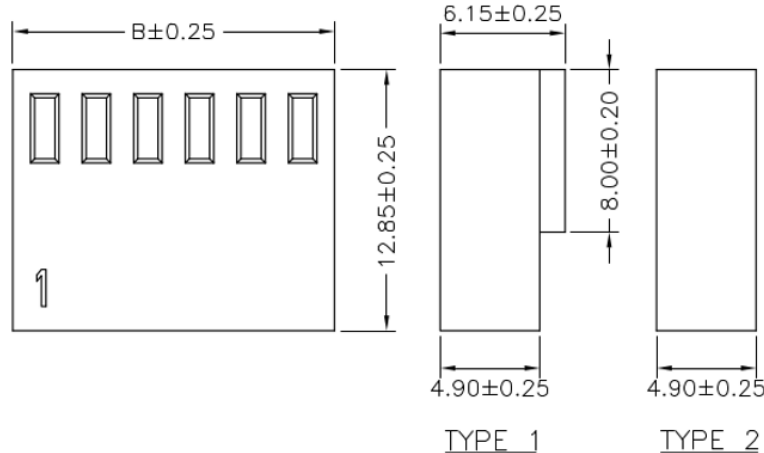
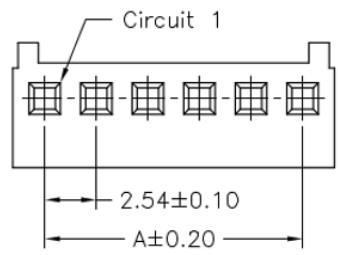

order information

D254402	xx	xx	xx	xx
No. of Positions	Type	Packaging	Special Customer	
02~20	1= Type 1	A= bag	xx= on request	
	2= Type 2	xx= on request		

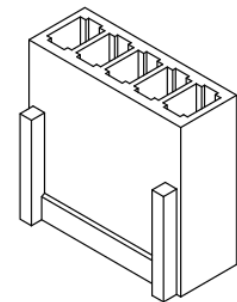

BRCONNECTORS

**Single Row Housing
Straight Type**

Tolerance: .X ± 0.25 .XX ± 0.15 .XXX ± 0.05	PROJECTON				
	DATE	03.08.2017	Customer Drawing- No.:		
	DRAWN	MR	Drawing- No.: 2161372		
	CHECKED	BR			
APPROVED	BR		UNIT: mm	SCALE:	SIZE: A4

D
C
B
A

D
C
B

4

3

2

1

Diese Zeichnung ist ausdrücklich Eigentum der BR-connectors GmbH. Ohne vorherige Zustimmung seitens der BR-connectors GmbH darf diese nicht vervielfältigt, noch an Dritte zugänglich gemacht werden. Wir behalten uns alle Rechte vor, auch im Falle einer Patentierung nach Gebrauchsmusterprüfung.

4

3

2

1

RoHS REACH compliant

REVISION DATA				
SYM	REV	DESCRIPTION	DATE	APPR.
	00	new part	03.08.17	MR

Technical Specification

Current Rating: 4A AC,DC
Voltage Rating: 250V AC,DC
Temperature: -25°C to +85°C
high temperature: -40°C to +105°C
Contact Resistance: 10mΩ
Insulation Resistance: 1000MΩ
Withstanding Voltage: 1000V AC/minute
Type: AWG #24 to #30, O.D.: 1.57mm (max)
Material: Phosphor Bronze

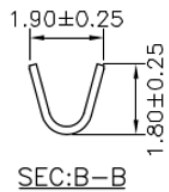
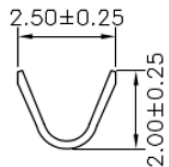
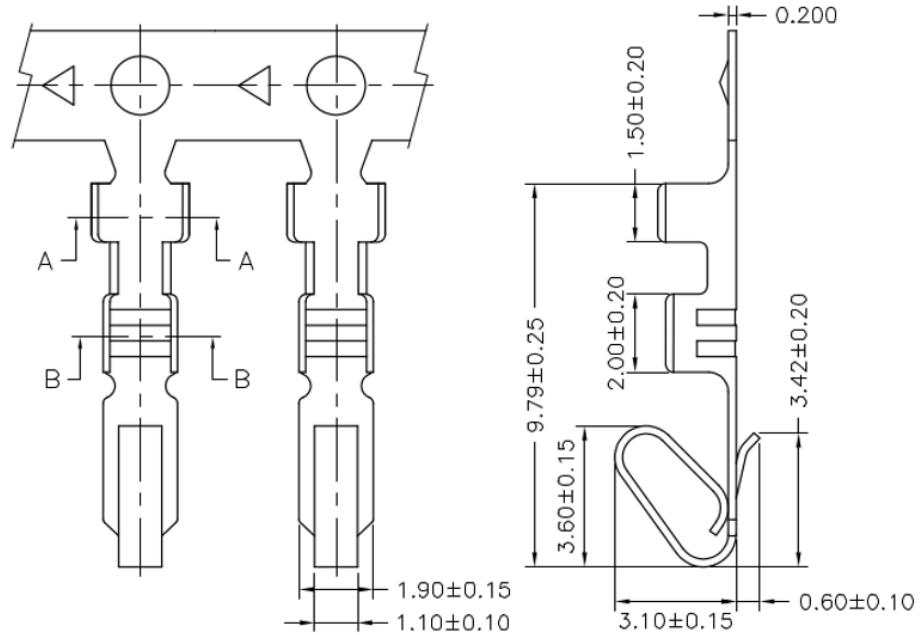

order information

E254402	xx	xx	xx
Plating Option	Packaging	Special Customer	
01= gold flash	D= tape&reel	xx= on request	
100= tin	xx= on request		
xx= on request			

		Terminal Crimp		
Tolerance: .X ± 0.25 .XX ± 0.15 .XXX ± 0.05	PROJECTON			
	DATE	03.08.2017	Customer Drawing-No.:	
	DRAWN	MR	Drawing-No.: 2161371	
	CHECKED	BR		
	APPROVED	BR	UNIT:	SCALE: